



Slide unit SC□L Type

(SMA□W Type)



SC□L

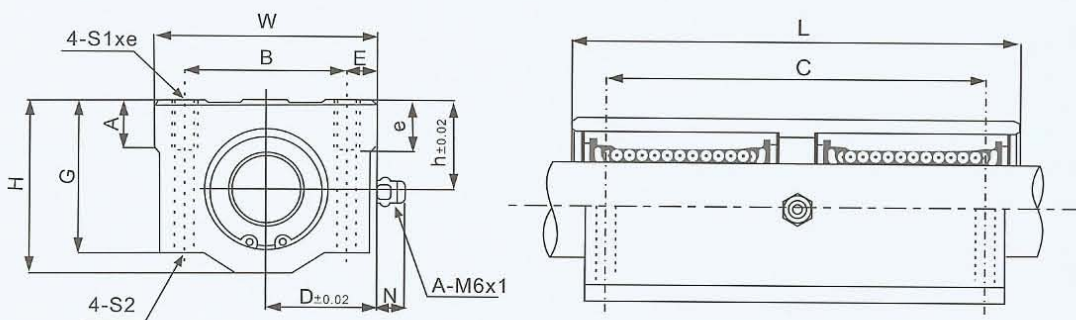

Part No.	Main dimensions (mm)													Basic Load Rating		Weight (g)
	h	D	W	H	G	N	A	B	E	S1xe	S2	C	L	C N	Co N	
SC8LUU	11	17	34	22	18	7	6	24	5	M4x8	3.4	42	58	431	784	102
SC10LUU	13	20	40	26	21	7	8	28	6	M5X12	4.3	46	68	588	1100	180
SC12LUU	15	21	42	28	24	6.5	8	30.5	5.75	M5X12	4.3	50	70	813	1570	250
SC13LUU	15	22	44	30	24.5	6.5	8	33	5.5	M5X12	4.3	50	75	813	1570	240
SC16LUU	19	25	50	38.5	32.5	6	9	36	7	M5X12	4.3	60	85	1230	2350	400
SC20LUU	21	27	54	41	35	7	11	40	7	M6X12	5.2	70	96	1410	2740	570
SC25LUU	26	38	76	51.5	42	4	12	54	11	M8X18	7	100	130	1610	3140	1200
SC30LUU	30	39	78	59.5	49	5	15	58	10	M8X18	7	110	140	2450	5490	1480
SC35LUU	34	45	90	68	54	5.5	18	70	10	M8X18	7	120	155	2650	6270	2200
SC40LUU	40	51	102	78	62	5	20	80	11	M10X25	8.7	140	175	3430	8040	3200
SC50LUU	52	61	122	102	80	5	25	100	11	M10X25	8.7	160	215	6080	15900	6700