



# Slide unit SC Type

(SMA Type)



SC

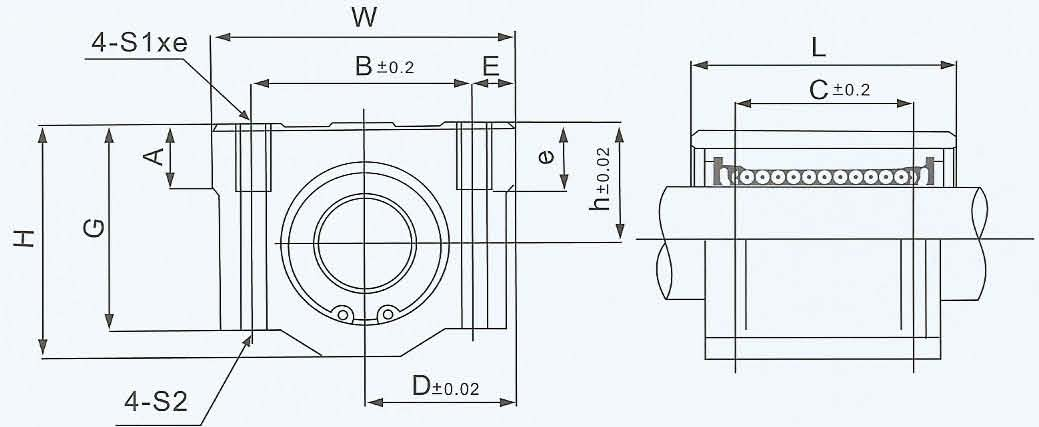

Part No.	Main dimensions (mm)												Basic Load Rating		Weight (g)
	h	D	W	H	G	A	B	E	S1xe	S2	C	L	C N	Co N	
SC8UU	11	17	34	22	18	6	24	5	M4X8	3.4	18	30	274	392	52
SC10UU	13	20	40	26	21	8	28	6	M5X12	4.3	21	35	372	549	92
SC12UU	15	21	42	28	24	8	30.5	5.75	M5X12	4.3	26	36	510	784	102
SC13UU	15	22	44	30	24.5	8	33	5.5	M5X12	4.3	26	39	510	784	120
SC16UU	19	25	50	38.5	32.5	9	36	7	M5X12	4.3	34	44	774	1180	200
SC20UU	21	27	54	41	35	11	40	7	M6X12	5.2	40	50	882	1370	255
SC25UU	26	38	76	51.5	42	12	54	11	M8X18	7	50	67	980	1570	600
SC30UU	30	39	78	59.5	49	15	58	10	M8X18	7	58	72	1574	2740	735
SC35UU	34	45	90	68	54	18	70	10	M8X18	7	60	80	1670	3140	1100
SC40UU	40	51	102	78	62	20	80	11	M10X25	8.7	60	90	2160	4020	1590
SC50UU	52	61	122	102	80	25	100	11	M10X25	8.7	80	110	3820	7940	3340