



Slide Unit SK Type

(SH-A Type)



SK

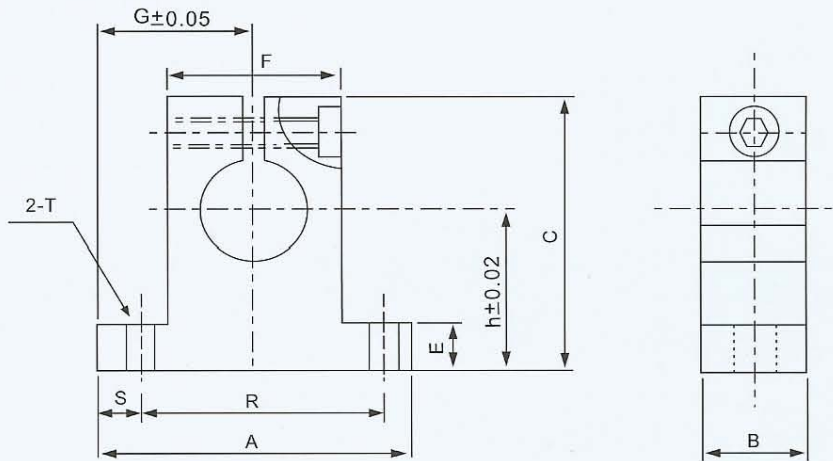

Part No.	Shaft diameter	Main dimensions (mm)										Clamping bolt designation	Mounting bolt designation	Weight (g)
		h	G	A	B	C	E	F	R	S	T			
SK-8	8	20	21	42	14	32.8	6	18	32	5	5.5	M4	M5	24
SK-10	10	20	21	42	14	32.8	6	18	32	5	5.5	M4	M5	24
SK-12	12	23	21	42	14	37.5	6	20	32	5	5.5	M4	M5	30
SK-13	13	23	21	42	14	37.5	6	20	32	5	5.5	M4	M5	30
SK-16	16	27	24	48	16	44	8	25	38	5	5.5	M4	M5	40
SK-20	20	31	30	60	20	51	10	30	45	7.5	6.6	M5	M6	70
SK-25	25	35	35	70	24	60	12	38	56	7	6.6	M6	M6	130
SK-30	30	42	42	84	28	70	12	44	64	10	9	M6	M8	180
SK-35	35	50	49	98	32	82	15	50	74	12	11	M8	M10	270
SK-40	40	60	57	114	36	96	15	60	90	12	11	M8	M10	420
SK-50	50	70	63	126	40	120	18	74	100	13	14	M12	M12	750